

BL350IC 3.5" LED Recessed Housings

Project:	
Type:	
Catalog #:	

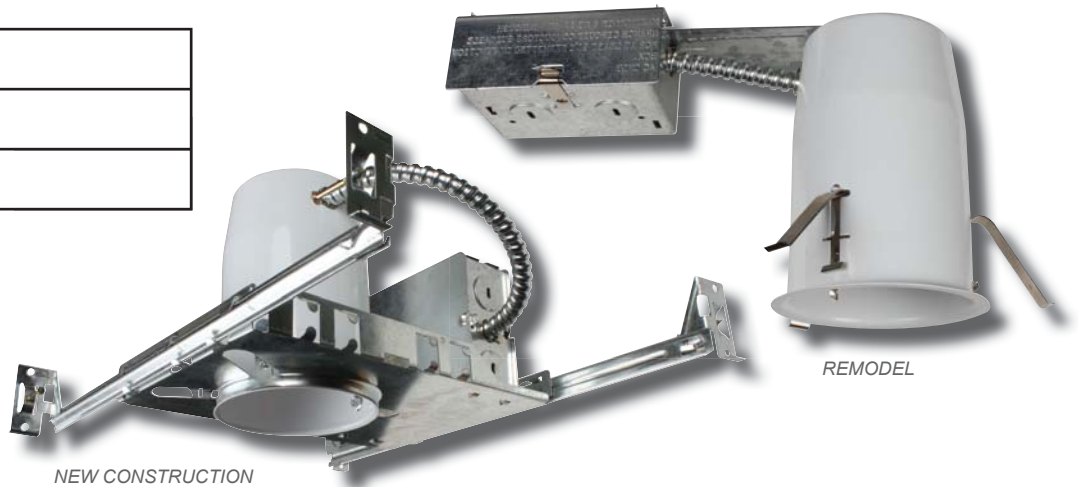

STANDARD



APPLICATIONS

- 3.5" recessed cans for new construction as well as remodel applications.
- Dedicated housings for LED trims/modules.

ILLUMINATION

- Lumen output dependant upon LED trim/module used.

ELECTRICAL

- 2-pin snap-on connector for easy connection to LED trims/modules.

MOUNTING

- Bar hangers on new construction model are adjustable from 13 $\frac{5}{8}$ " to 25" and can be repositioned 90° on plaster frame.
- Four clips on remodel cans provided to secure to housing and accommodate $\frac{1}{2}$ " and $\frac{3}{8}$ " ceilings.
- Pre-installed real nail on new model cans easily installs in regular and engineered lumber.

HOUSING

- Galvanized steel construction.
- Contains one 1 $\frac{1}{8}$ ", six $\frac{7}{8}$ " knockouts and four romex pryouts with stain relief.
- Housing on new construction model can be removed from frame to provide access to the junction box.

WARRANTY/LISTING

- cULus listed for damp locations.
- Meets State of California Title 24 requirements.
- Five year warranty.
- Certified under ASTM-E283 for air tight construction.

DIMENSIONS

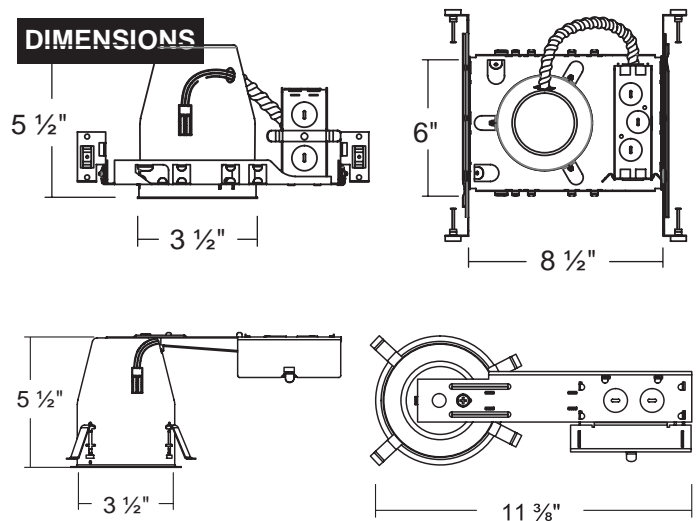

ORDERING INFORMATION

MODEL	DESCRIPTION
BL350ICATLEDNND-QN	3 $\frac{1}{2}$ " Dedicated LED IC housing for new construction applications
BL350ICATLEDRND-Q	3 $\frac{1}{2}$ " Dedicated LED IC housing for remodel applications